



# USER MANUAL

**1 Channel Controller:  
SDA Series**

Hardware.....	1
Packing List.....	1
General Description.....	2
Specification of SDA-M and SDA-CH1-A2.....	2
Connections.....	3
Panel Label Description.....	5
SDA-M.....	5
SDA-CH1-A2.....	6
SDA-M and SDA-CH1-A2 Operation Mode.....	7
Auto Restart.....	7
Continuous Mode.....	7
Pulse Mode.....	8
Calibration.....	9
Adjustable cut-off temperature.....	9
SDA Series Software.....	10
Change IP Address.....	12
Cascade Operation.....	13
Cascade Connection.....	14
CAN BUS Multi-Drop Connection.....	15
Output Signal.....	16
Input Signal .....	16
Drawing.....	17
Accessories .....	19
24V Power Supply .....	19
Cable Selection .....	20
Cable Information .....	21
Power Cord Information .....	22

REV	Author	Remark
1.0	ZW	First Draft
1.1	ZW	Added trigger input signal & update software download link
1.2	Kok Hwa	Minor Updates

## HARDWARE

### PACKING LIST

Please ensure the following items are in the package:

#### SDA Series Controller Package

- SDA-CH1-X2
  - SDA-M Controller Unit x1
  - SDA-CH1-A2 Controller Unit x1
- Ethernet Crossover Cable x1
- RJ11 Cable x1
- User Manual x1
- User Interface (*download from below link\**)

#### **Repeat order package**

#### SDA-M Controller Package

- SDA-M Controller Unit
- Ethernet Crossover Cable
- User Manual (*download from below link\**)

#### SDA-CH1-A2 Controller Package

- SDA-CH1-A2 Controller Unit
- RJ11 Cable
- User Manual (*download from below link\**)

**\*Download user interface & user manual**

<https://www.visionlux.net/product/sda-series-led-light-controller/>

# General Description

The SDA series controller provides intensity control of LED lighting for machine vision applications. The lighting controller unit comprised of a master controller and at least one channel controller.

1. Master controller: SDA-M
2. Channel/Slave Controller: SDA-CH1-A2

SDA-M functions as to transfer the command from the software to SDA-CH1-A2.

SDA-CH1-A2 responds to the commands from SDA-M, then control the lighting output.

The controller consists of 2 modes of operation (continuous and pulse mode).



## SPECIFICATION OF SDA-M AND SDA-CH1-A2

<b>Lighting Output</b>	No. of lighting output	1 per channel
	Min. current output	40mA
	Voltage	Continuous Mode: 24V Pulse Mode: 50V Max
	Output current	Continuous Mode: 2A Max Pulse Mode: 6A Max
<b>Input</b>	No. of input	1 per channel
<b>Output</b>	No. of output	1 per channel
<b>Input Power Supply</b>	Power rating	24V
	Input current	Minimum 2.5x LED Light
<b>Control</b>	Control Method	TCP/IP (Ethernet)
	Auto restart	Yes

### Remark:

- Maximum lighting rating can be applied is  $2A \pm 10\%$ . Fail to do so may cause the controller malfunction.
- For Windows 7 64 bit may possibly cause connection failure.
- PC must pre-install .Net 4.0 framework & Visual C++ redistributable 2015.

# General Description

## CONNECTIONS

### SDA-M

Terminal	Function
24V	Controller Power Supply +
GND	Controller Power Supply –
Ethernet	User Interface
RESET	Reset IP address to default value
CAN (2 terminals)	CAN BUS (Cascade Operation)

### SDA-CH1-A2

Terminal	Function
24V	Controller Power Supply +
Gnd	Controller Power Supply –
LI +	Lighting Output +
LI –	Lighting Output –
OUT +	External Device Output +
OUT –	External Device Output –
IN +	External Input + (3.3V – 24V)
IN –	External Input –
GND	Ground Connection
TEMP +	Temperature Sensor +
TEMP –	Temperature Sensor –
CAN (2 terminals)	CAN BUS (Cascade Operation)
CH ID	5 Way DIP Switch

# General Description

## SDA-CH1-A1 Connection (NPN)

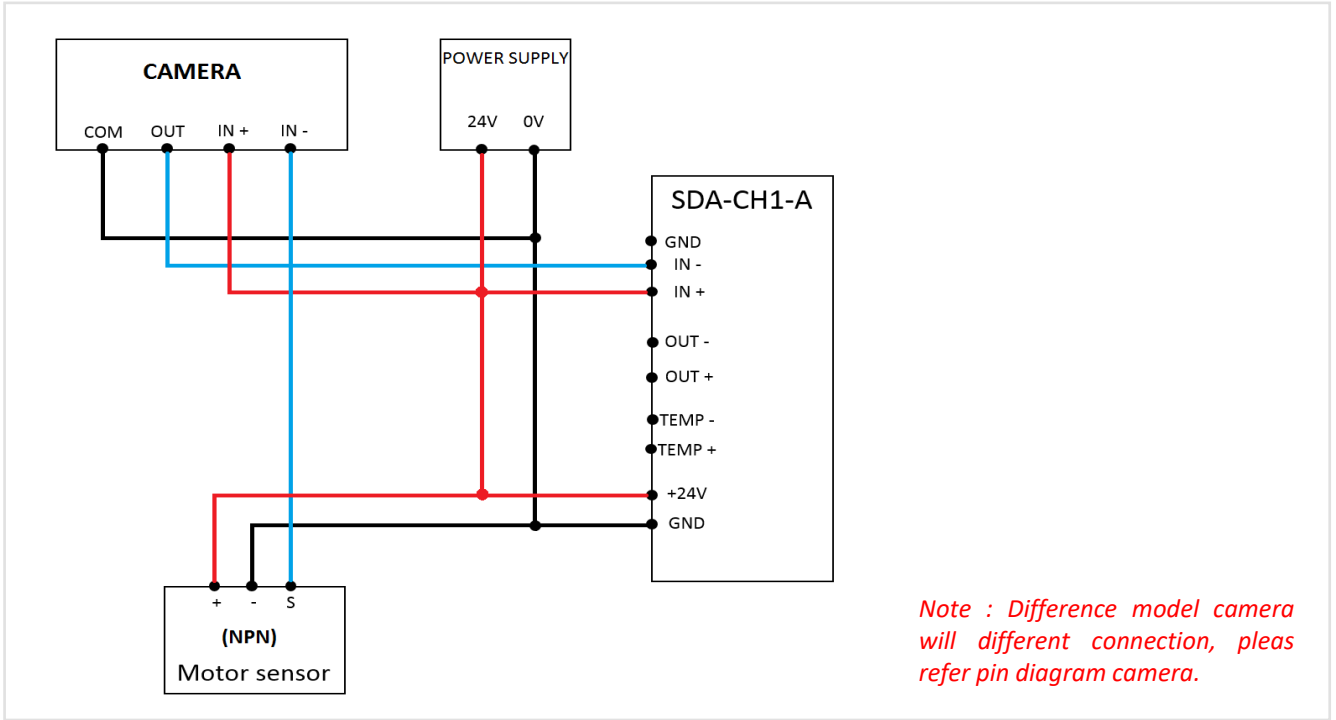

## SDA-CH1-A1 Connection (PNP)

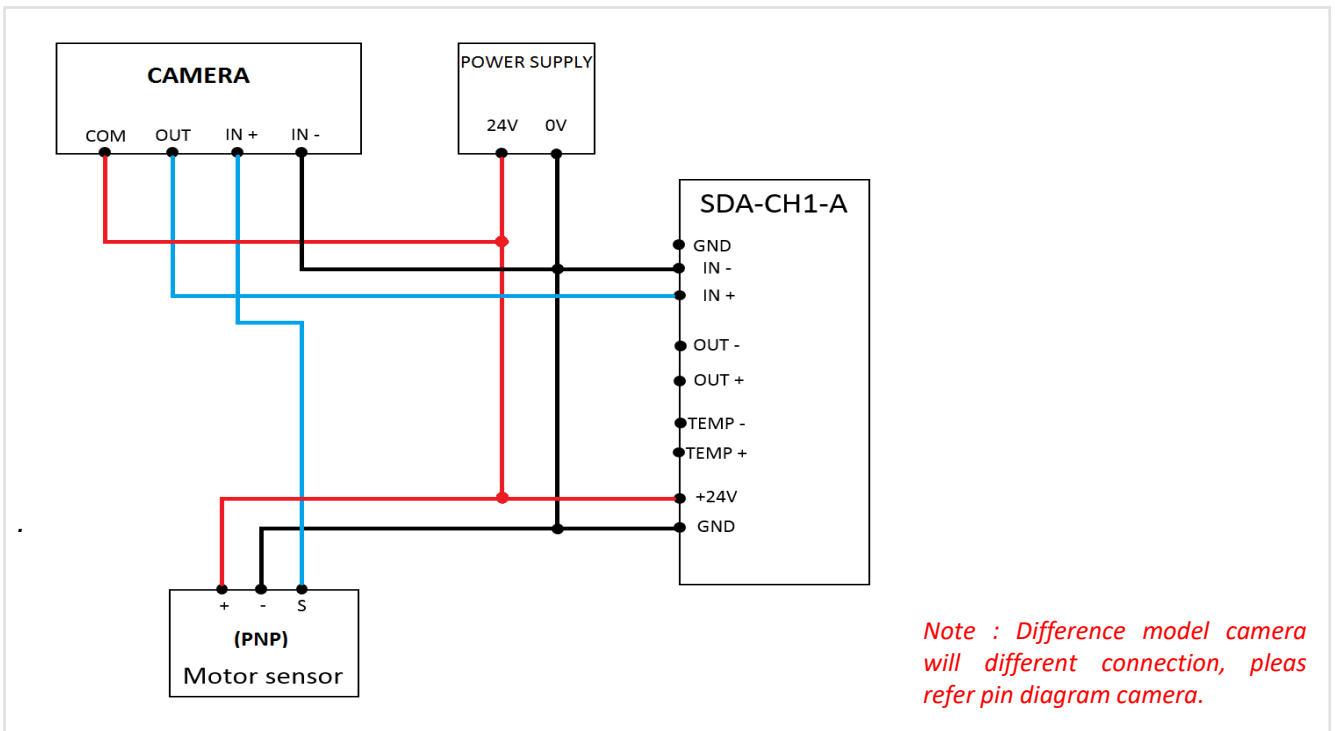

# General Description



## PANEL LABEL SDA-M

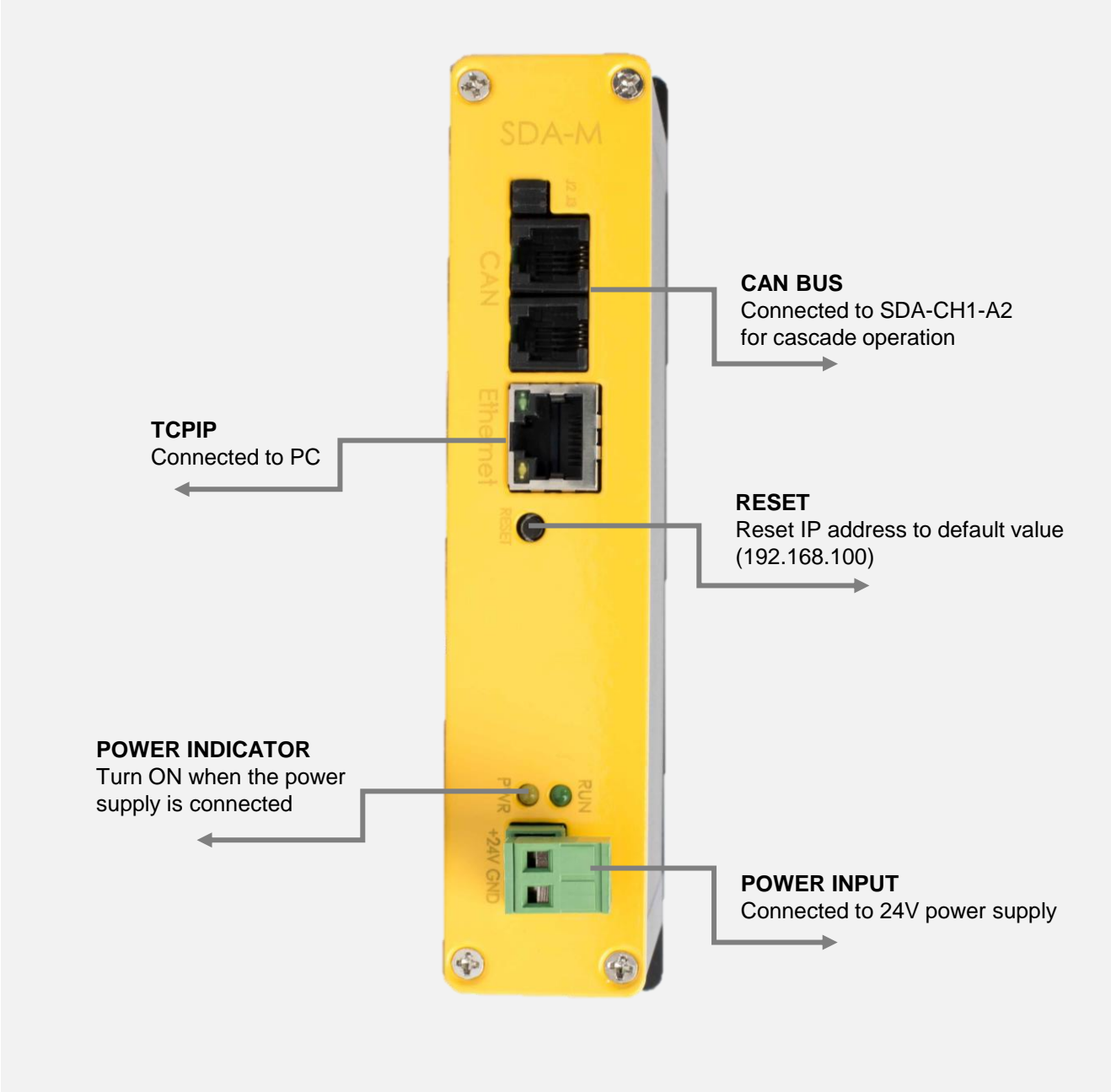

# General Description

## PANEL LABEL SDA-CH1-A2

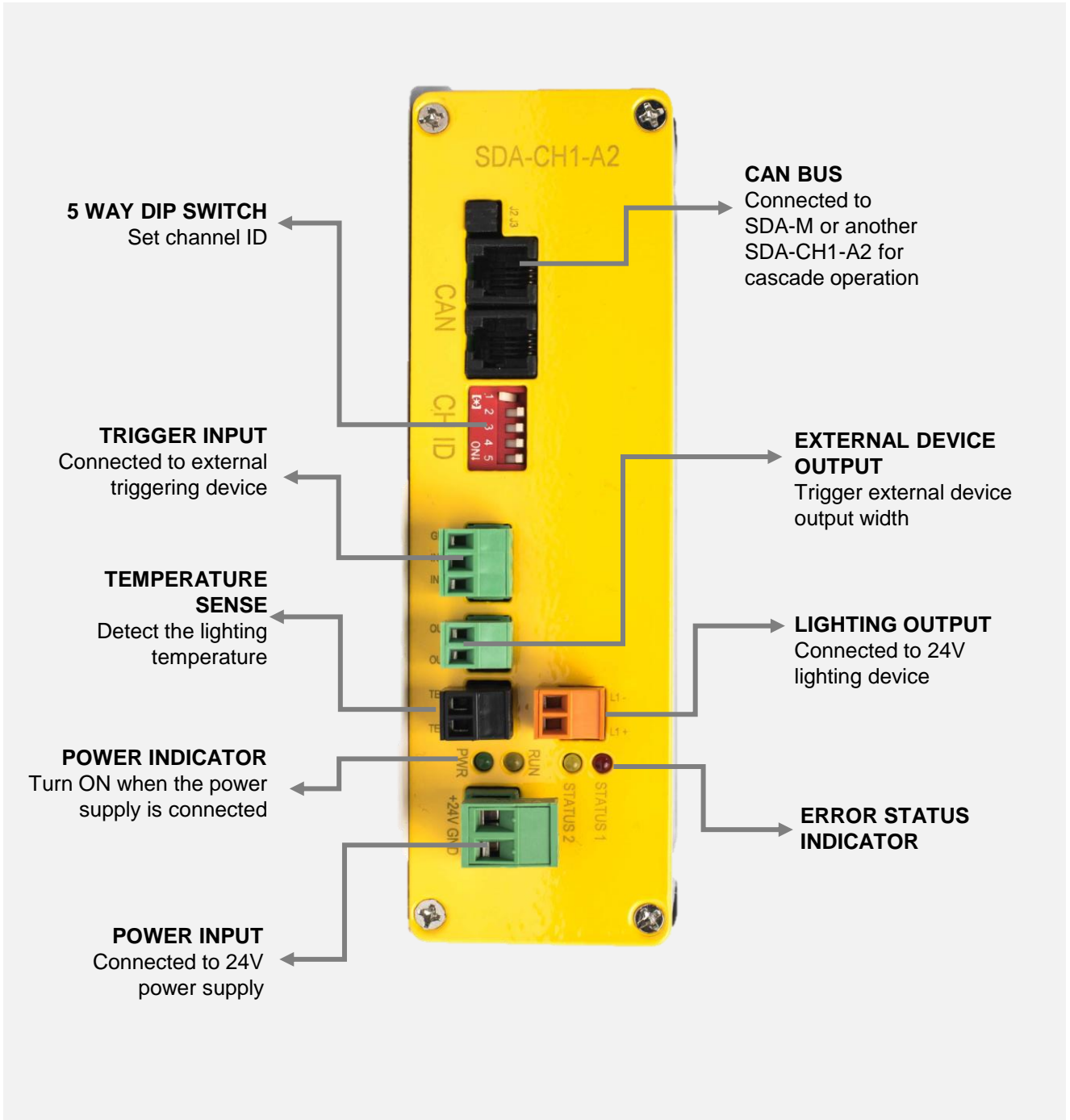

## SDA-M and SDA-CH1-A2 Operation Mode

Each channel can operate in 2 different modes: continuous mode and pulse mode.

### AUTO RESTART

Without UI – SDA able to auto restart once power is turned on. SDA apply current according to saved parameter. Error will occur once the tolerance of detected current is more than  $\pm 20\%$  of saved current.

With UI – SDA is able to reset & save the parameter wanted.

### CONTINUOUS MODE

Continuous mode offers continuous lighting intensity control. Brightness can be adjusted from fully OFF (0%) to fully ON (100%).

Lighting intensity is controlled by setting the percentage in the SDA Series Software. The intensity is changed via Pulse Width Modulation (PWM) technique. Current is switched between 0 and maximum lighting current at a high frequency. The ratio of ON to OFF determines the lighting brightness.

e.g. When the intensity is set to be 25%, the current flow (ON time) will be 25% of a cycle, then being turned off for the remaining 75% of the cycle.

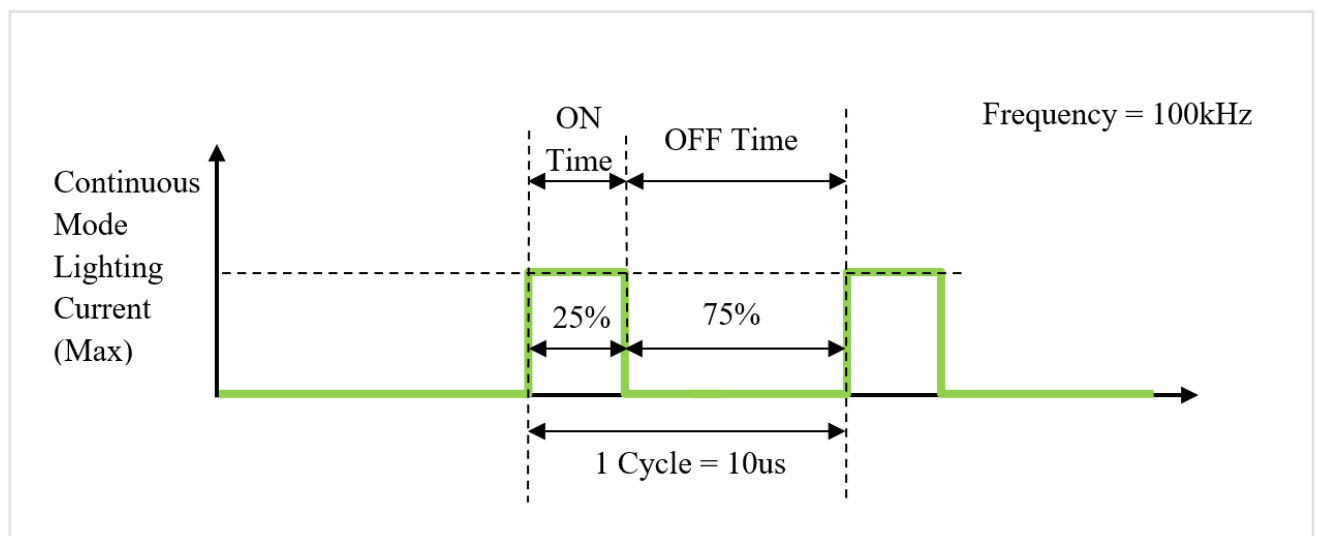

## PULSE MODE

An input trigger signal will ON the light and activates the lighting output based on pre-set pulse trigger delay and pulse width. Pulsing provides high current short interval triggering for applications that require high intensity and high precision.

Overdrive percentage is the amplification of the current and voltage applied on the lighting. As the overdrive percentage increases, the brightness of the lighting also increases.

Pulse width is the duration of the lighting ON time.

Pulse trigger delay is the duration of the delay time between the trigger external input signal and the lighting output. The lower the pulse trigger delay, the faster the lighting device lights ON upon receiving the trigger signal.

Adjust pulse width and pulse trigger delay in order to start running the lighting after “Restart”.

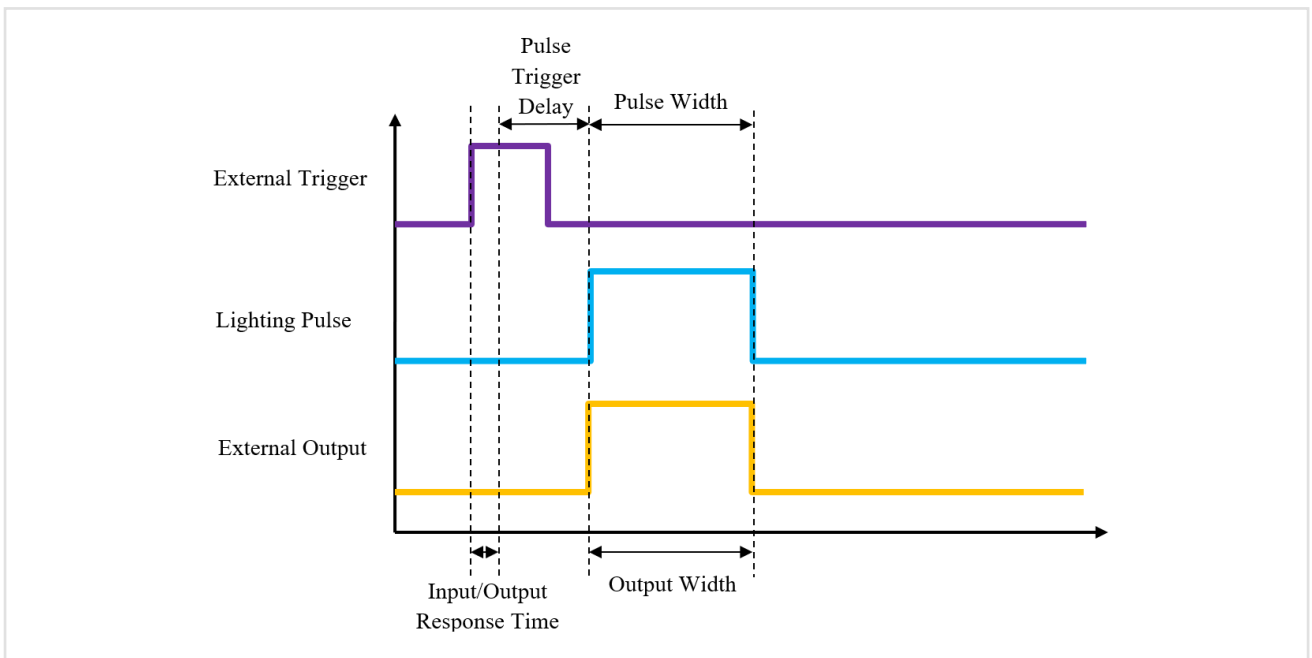

### Remark:

- *Maximum pulse width is 10,000us and maximum duty cycle for lighting pulse is 10%. Fail to do so may cause the controller malfunction.*
- *User can modify the other 2 parameters (Pulse Trigger Delay, Pulse Width)*
- *Input response time is <1us*
- *Output response time is <3us*
- *External trigger frequency must be less than 33 kHz for controller to work properly.*
- *The Output Width follows the same pattern as the Lighting Pulse Width Calibration*

# General Description

The function of calibration is to set the current directly that user wants (within  $\pm 20\%$  tolerance of lighting current at 24V).

When user saves parameter settings to controller using “Save Param To Flash” function in SDA Series Software, the current that supplied by controller will be saved as well. If a different lighting is to be used, the controller will read back its current during initialization. If the new lighting is able to support the saved current (within  $\pm 20\%$  tolerance of lighting current at 24V), controller will continue supply the saved current. If the saved current cannot be supported by the new lighting (not within  $\pm 20\%$  tolerance of new lighting current at 24V), controller will supply supported current (within  $\pm 20\%$  tolerance of new lighting current at 24V) closest to the saved current.

If user wants a lower/higher current, user can set the rated current using calibration button, provided the set current is within  $\pm 20\%$  tolerance of new lighting current at 24V.

## Example 1: Calibration with new higher current lighting

Setup 1	Setup 2
Illuminator A	Illuminator B
LBRX-00-080-3-R-24V	LSW-30-090-4-R-24V
24V/150mA/3.6W	24V/345mA/8.28W

If setup 1 is set to 150mA, after changing to setup 2, controller will supply 240mA ( $345\text{mA} \times 0.8 = 276\text{mA}$ ) which is the minimum current illuminator B can support ( $-20\%$  tolerance).

## Example 2: Calibration with same range current lighting

Setup 1	Setup 2
Illuminator A	Illuminator B
LBRX-00-080-3-R-24V	LBRX-00-080-6-R-24V
24V/150mA/3.6W	24V/160mA/3.84W

If setup 1 is set to 150mA, after changing to setup 2, controller will still continue to supply 150mA which is within  $\pm 20\%$  current tolerance of set current (120mA – 180mA).

## Adjustable cut-off temperature

Cut off temperature:  $40^{\circ}\text{C} - 100^{\circ}\text{C}$

SDA will cut off supply current when temperature detected is exceed cut off temperature been set.

10K thermistor is suit to SDA controller.

# General Description

## SDA SERIES SOFTWARE

The controller can be controlled using SDA Series software. Connect the controller to computer with Ethernet crossover cable.

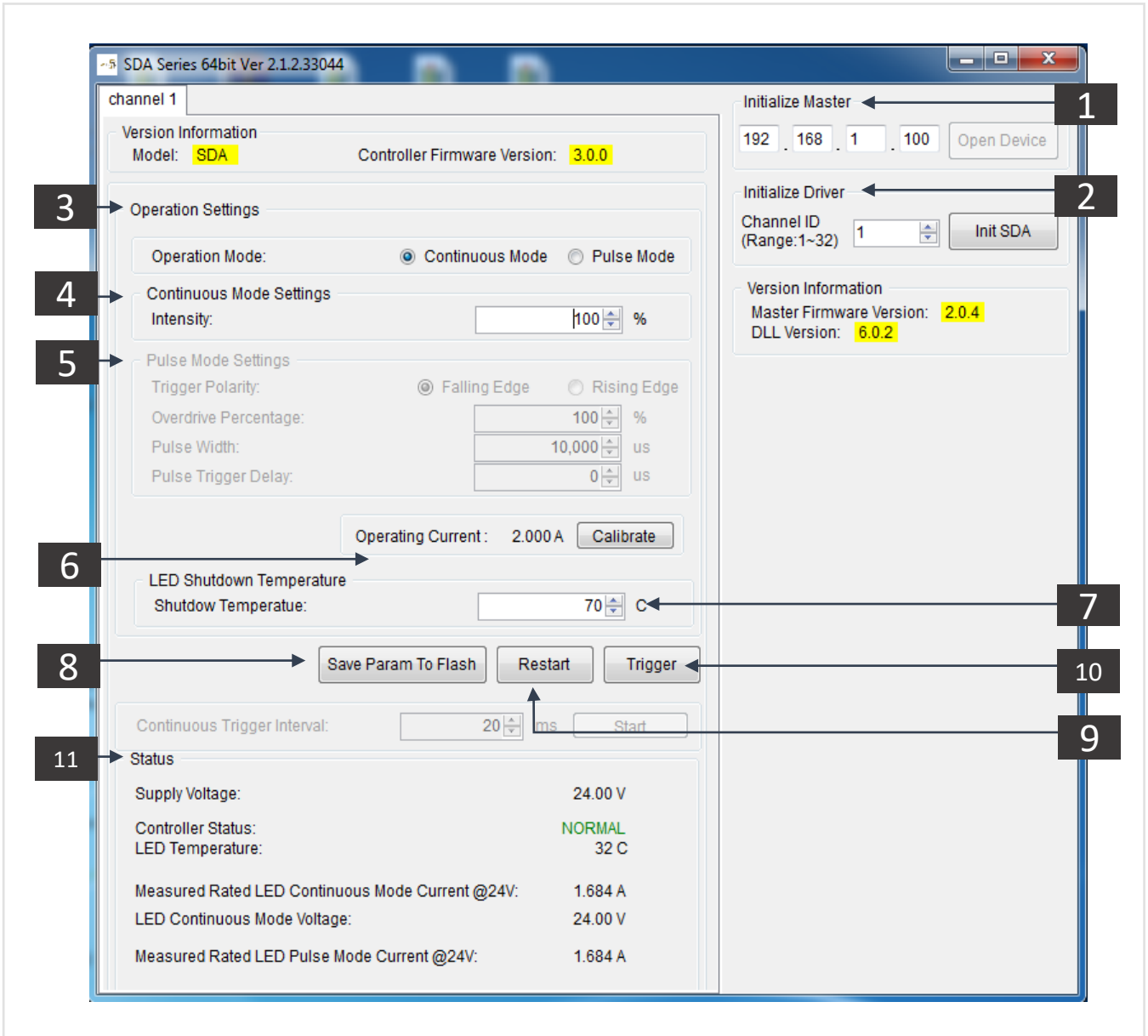

### Remark:

- For Windows 7 64 bit may possibly cause connection failure.
- PC must pre-install .Net 4.0 framework & Visual C++ redistributable 2015.

# General Description



1	Initialize Master	<ul style="list-style-type: none"> <li>• Open Device: To connect controller to the PC</li> <li>• Flexible IP address: Default IP address at 192.168.1.1003</li> </ul>
2	Initialize driver	<ul style="list-style-type: none"> <li>• Init SDA: Select the channel ID (range: 1-32)</li> <li>• Connect to SDA-CH1-A2</li> </ul>
3	Operation settings	<ul style="list-style-type: none"> <li>• Select mode for channel <ul style="list-style-type: none"> <li>- Continuous mode</li> <li>- Pulse mode</li> </ul> </li> </ul>
4	Continuous Mode Setting	<ul style="list-style-type: none"> <li>• Intensity: Change intensity of lighting (min: 0%, max: 100%, step: 1%)</li> </ul>
5	Pulse Mode Setting	<ul style="list-style-type: none"> <li>• Overdrive Percentage: Set lighting overdrive (min: 100%, max: 600%, step: 10%)</li> <li>• Pulse Width: Duration of pulse signal (min: 1us, max: 10,000us, step: 1us)</li> <li>• Pulse Trigger Delay: Delay time of pulse signal (min: 0us, max: 1,000,000us, step: 1us)</li> <li>• Trigger Polarity: Falling/Rising Edge</li> </ul>
6	Operating current	<ul style="list-style-type: none"> <li>• Set rated current within tolerance (<math>\pm 20\%</math> of LED Continuous Mode Current)</li> </ul>
7	LED shutdown temperature	<ul style="list-style-type: none"> <li>• Minimum: 40°C</li> <li>• Maximum: 100°C</li> <li>• Default: 70°C</li> </ul>
8	Save Parameter to Flash	<ul style="list-style-type: none"> <li>• Save parameter settings and supplied current value</li> </ul>
9	Restart	<ul style="list-style-type: none"> <li>• Restart controller</li> <li>• Re-calculate power consumption of the lighting</li> </ul>
10	Status	<ul style="list-style-type: none"> <li>• LED Continuous Mode Current: Current of lighting in continuous mode</li> <li>• LED Pulse Mode Current: Current of lighting in pulse mode</li> <li>• LED Temperature: Display temperature of lighting</li> <li>• Status: <ul style="list-style-type: none"> <li>➢ NORMAL: Controller can operate normally</li> <li>➢ OPEN CIRCUIT: SDA-CH1-A is not connected to lighting device</li> <li>➢ RESTARTING: Restart SDA-CH1-A</li> <li>➢ REQUIRED VOLTAGE TOO HIGH: Required lighting voltage is too high (required voltage <math>\geq 50V</math>)</li> <li>➢ OVER CURRENT: Required lighting current is too high (Continuous Mode: <math>\geq 1A</math>, Pulse Mode: <math>\geq 6A</math>)</li> <li>➢ OVER TEMPERATURE: Temperature <math>\geq</math> configured cut-off temperature</li> <li>➢ DETECTED LED OUT OF RANGE: Current detected was out of the range of saved current.</li> </ul> </li> </ul>

## CHANGE IP ADDRESS

IP address must change before switch to function (Control Channel).

Example:

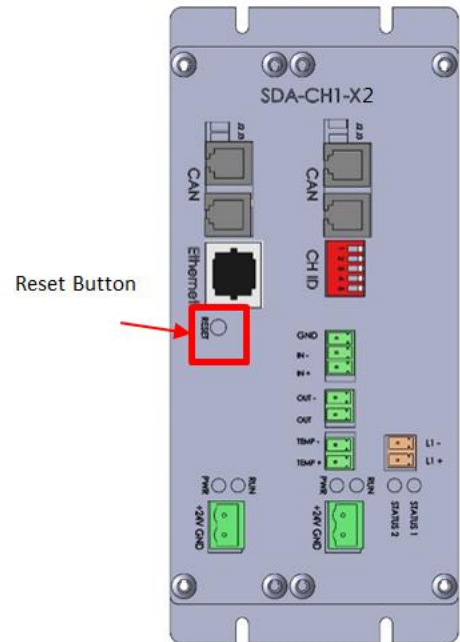
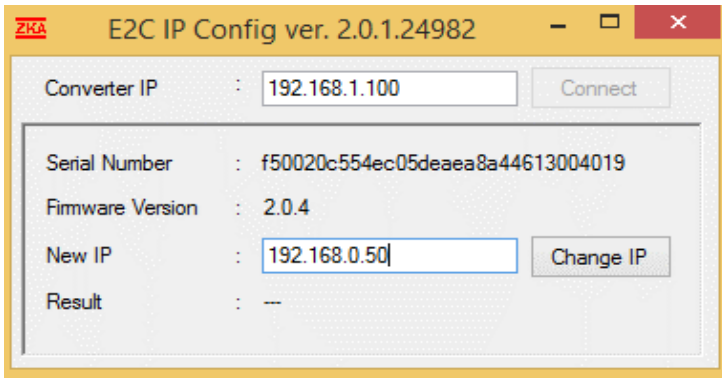

The new IP will be effective on next bootup.  
IP address is able to change back default value (192.168.1.100) by pressing "RESET" button 3 second.

Error will prompt out when key in wrong IP address.

Example:

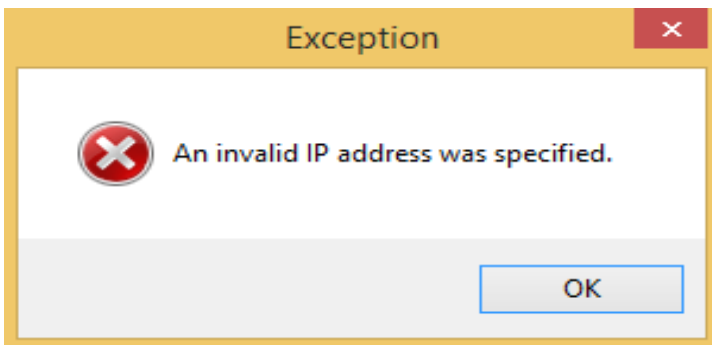

## CASCADE OPERATION

The SDA Lighting Controller can be used in cascade mode when there is more than 1 lighting output channel to be controlled at the same time.

The number of controller that can be connected in cascade is up to 32 where the ID of the controller is pre-set manually with 5 way DIP switch in binary code before power on controller. The SDA-CH1-A2 is connected to the SDA-M using RJ11 cable.

DIP SWITCH NO	1	2	3	4	5
BINARY VALUE	$2^0$	$2^1$	$2^2$	$2^3$	$2^4$
CHANNEL ID 1	1	0	0	0	0
CHANNEL ID 2	0	1	0	0	0
CHANNEL ID 3	1	1	0	0	0
CHANNEL ID 4	0	0	1	0	0
CHANNEL ID 5	1	0	1	0	0
CHANNEL ID 6	0	1	1	0	0
CHANNEL ID 7	1	1	1	0	0
CHANNEL ID 8	0	0	0	1	0
CHANNEL ID 9	1	0	0	1	0
CHANNEL ID 10	0	1	0	1	0
CHANNEL ID 11	1	1	0	1	0
CHANNEL ID 12	0	0	1	1	0
CHANNEL ID 13	1	0	1	1	0
CHANNEL ID 14	0	1	1	1	0
CHANNEL ID 15	1	1	1	1	0
CHANNEL ID 16	0	0	0	0	1
CHANNEL ID 17	1	0	0	0	1
CHANNEL ID 18	0	1	0	0	1
CHANNEL ID 19	1	1	0	0	1
CHANNEL ID 20	0	0	1	0	1
CHANNEL ID 21	1	0	1	0	1
CHANNEL ID 22	0	1	1	0	1
CHANNEL ID 23	1	1	1	0	1
CHANNEL ID 24	0	0	0	1	1
CHANNEL ID 25	1	0	0	1	1
CHANNEL ID 26	0	1	0	1	1
CHANNEL ID 27	1	1	0	1	1
CHANNEL ID 28	0	0	1	1	1
CHANNEL ID 29	1	0	1	1	1
CHANNEL ID 30	0	1	1	1	1
CHANNEL ID 31	1	1	1	1	1
CHANNEL ID 32	0	0	0	0	0



DIP Switch

## CASCADE CONNECTION

Connect one end of RJ11 cable to either CAN BUS socket of SDA-M and the other end to CAN BUS socket of SDA-CH1-A2.

To connect more SDA-CH1-A2, connect another RJ11 cable's one end to a connected SDA-CH1-A2 (e.g. ID 1) and the other end to another SDA-CH1-A2 (e.g. ID 2).

There are 2 jumpers (J2 and J3) beside CAN BUS socket. When connecting more than 1 SDA-CH1-A2, the brackets of the jumpers need to be removed for all controllers (SDA-M and/or SDA-CH1-A2) except the far left and far right ones.



**CAN BUS Socket and Jumpers (J2, J3)**



**Bracket of Jumpers removed**

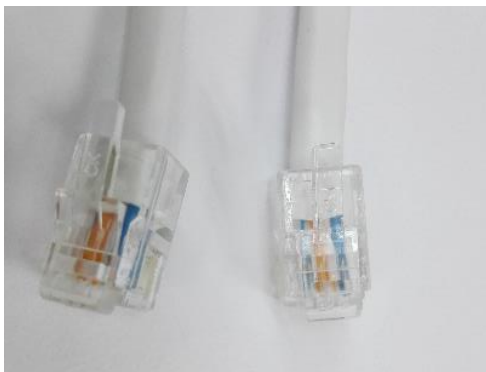

**End of RJ11 Cable**

All brackets of the jumpers are removed except far left and far right

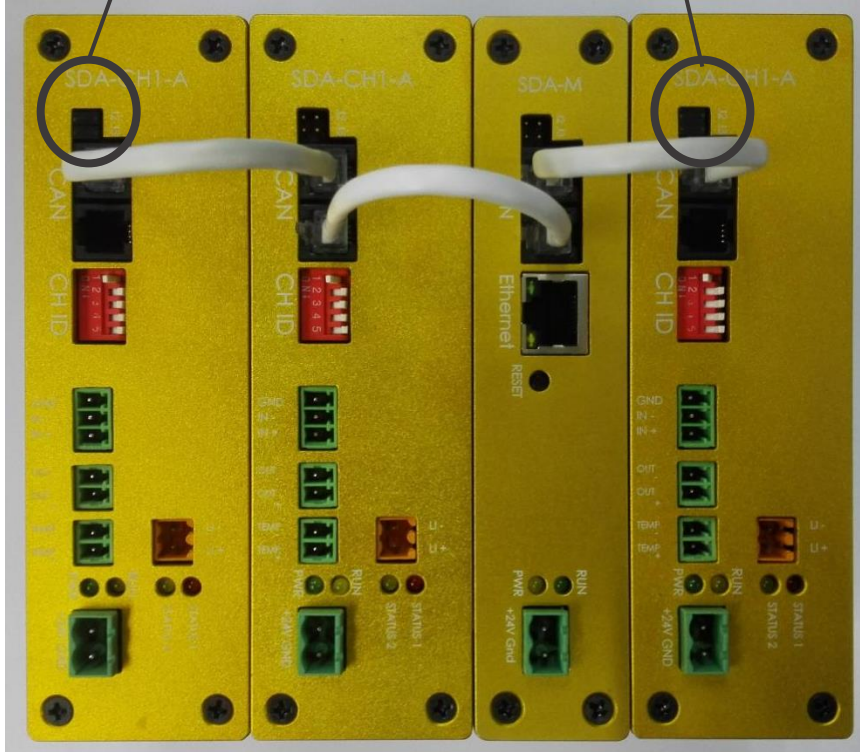

Example of Cascade Connection

## CAN BUS MULTI-DROP CONNECTION

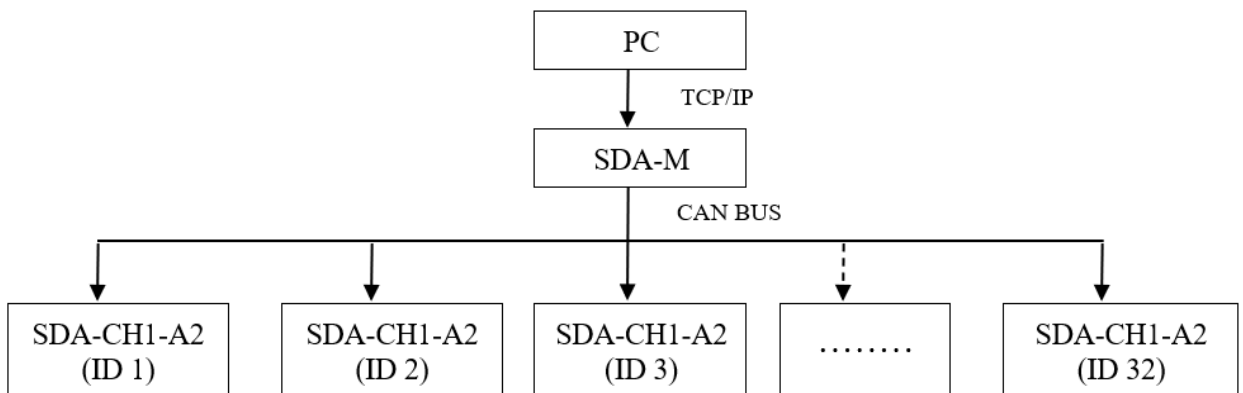

## OUTPUT SIGNAL

The output signal is optional and is used to trigger external devices such as smart camera. The output signal is only available in Pulse Mode.

The output pulse is triggered after a delay time defined by Pulse Trigger Delay.

There is one output for each SDA-CH1-A2. C(+) is Collector positive and E(-) is Emitter negative for the output. The output connections (Pull High or Pull Low Signal) are shown in the following figures.

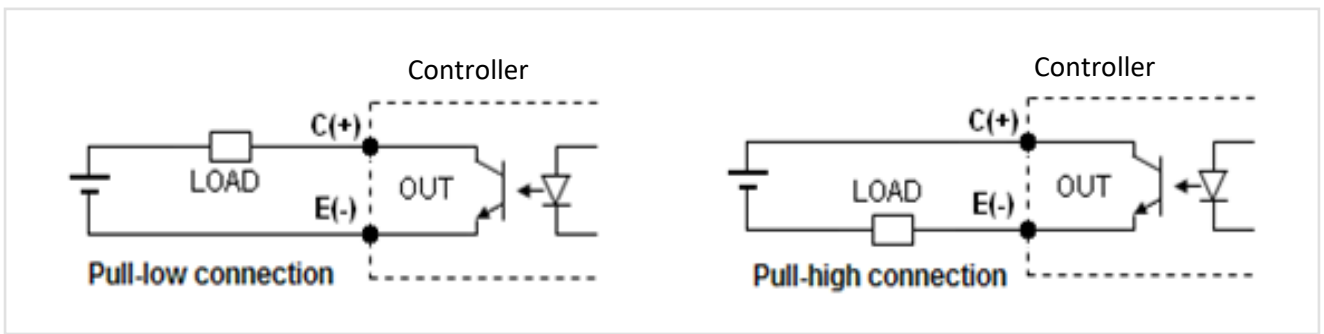

## INPUT SIGNAL

Input signal is optional and used to turn on the lighting-based frequency/duty cycle of input signal. The turn on time of lighting is adjustable and depending on the value of pulse width. Note: Pulse width adjustment from 0s to 10ms.

IN(+) is common positive input. Acceptable voltage is from 3.3-24VDC.

IN(-) is common negative input. Should be connected to GND.

The trigger signal can be acknowledged by controller on the rising edge or falling edge.

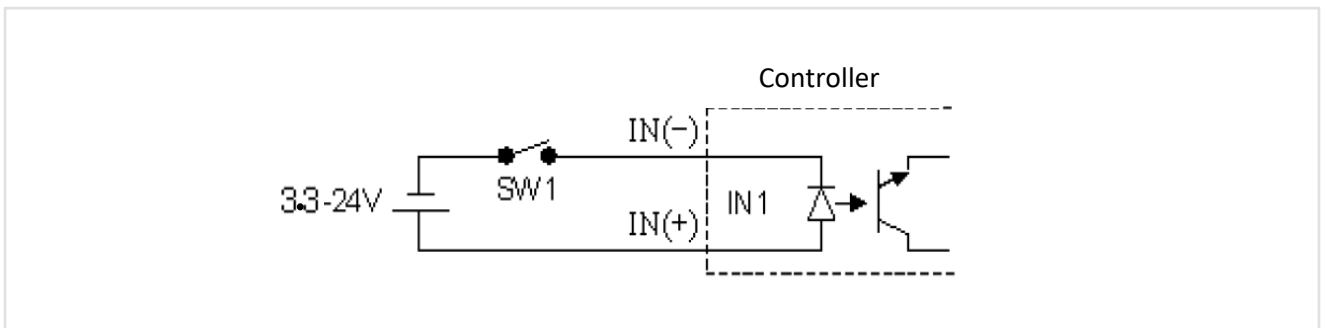

# General Description

## DRAWING LAYOUT SDA-M

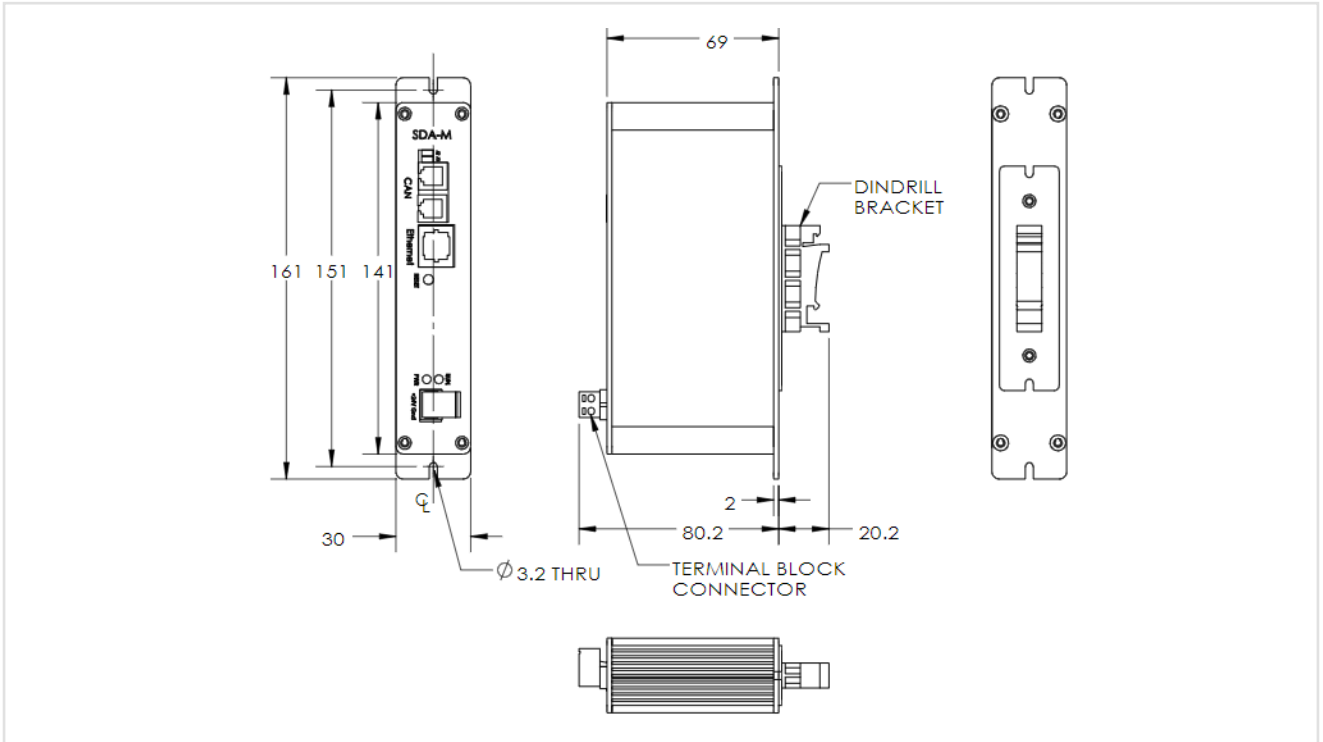

## DRAWING LAYOUT SDA-CH1-A2

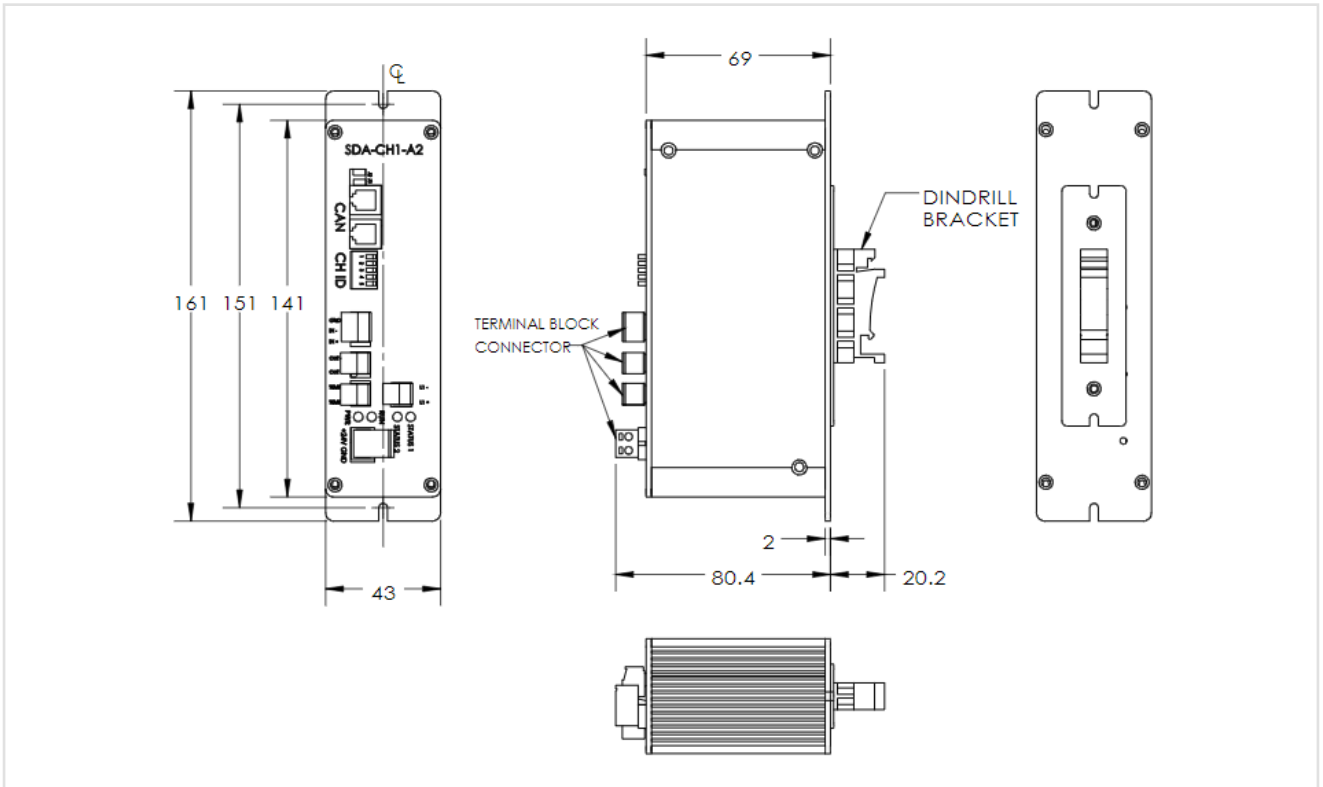

# General Description

## DRAWING LAYOUT SDA-CH1-X2

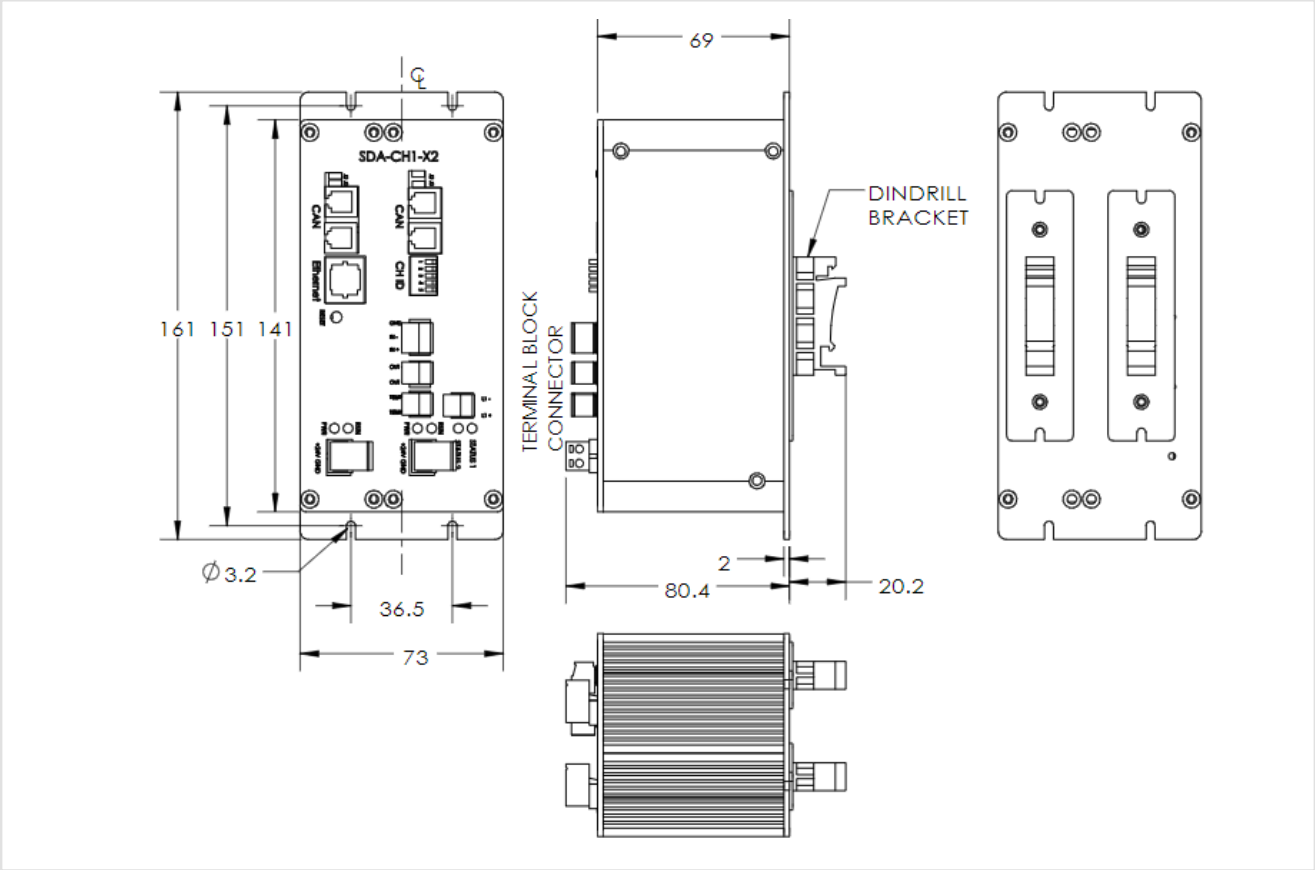

## ACCESSORIES

Additional accessories that can be used with SDA-M and SDA-CH1-A2 controllers.

- 24V Adaptor power supply
- Choose one Power Cord UK, US or EU

Model	Specification
 <p><b>24V ADAPTOR POWER SUPPLY WITH POWER CORD</b></p>	<ul style="list-style-type: none"> <li>• 24V-2.5A-UK (24V ADAPTOR WITH POWER CORD UK)</li> <li>• 24V-2.5A-US (24V ADAPTOR WITH POWER CORD US)</li> <li>• 24V-2.5A-EU (24V ADAPTOR WITH POWER CORD EU)</li> </ul>

## CABLE SELECTION

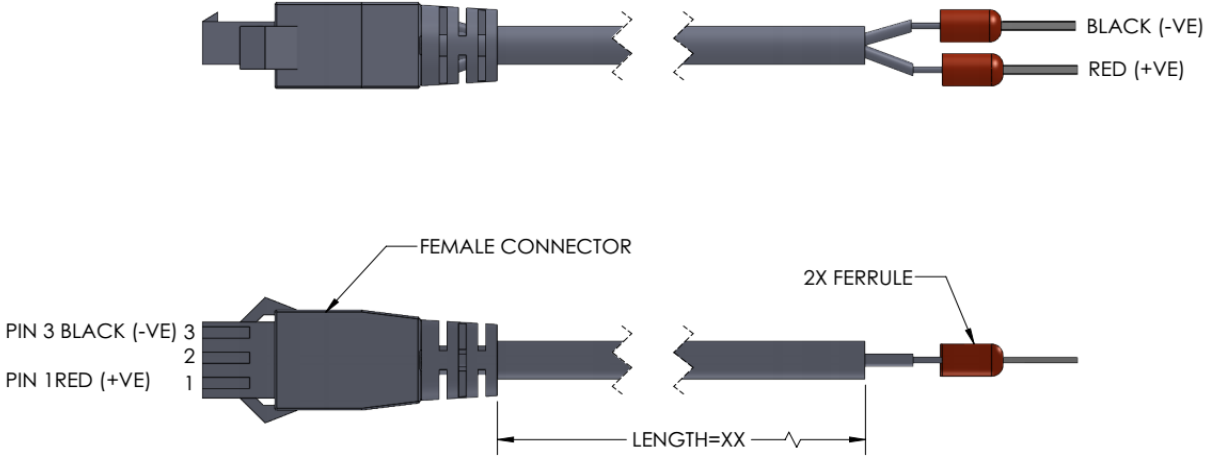

MODEL	POWER	LENGTH
EXT-24V-F-XX*	24V	3M
		5M

Remark: \* XX= Length

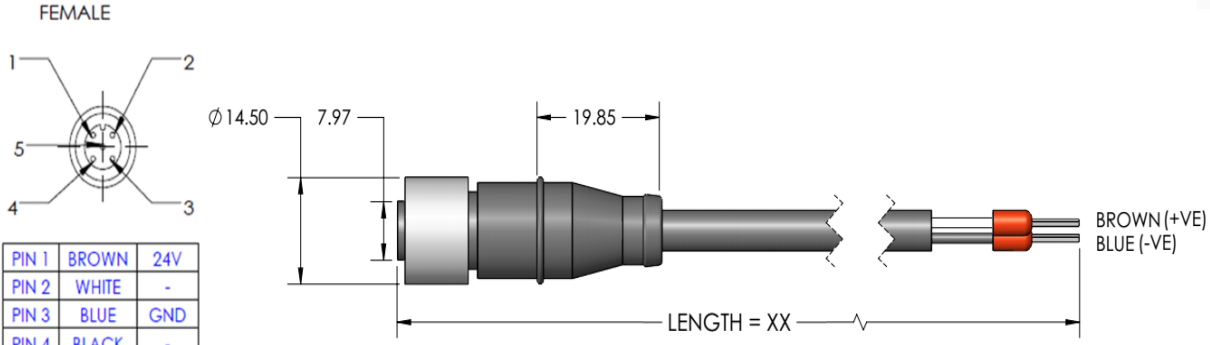

PIN	COLOR	FUNCTION
PIN 1	BROWN	24V
PIN 2	WHITE	-
PIN 3	BLUE	GND
PIN 4	BLACK	-
PIN 5	GRAY	-

MODEL	POWER	LENGTH
EXT-FL-M12F-XX*	24V	3M
		5M

Remark: \* XX= Length

## CABLE INFORMATION

### I) EXT-24V-F-3M

Extension Cable of 3 Meter with SM connector

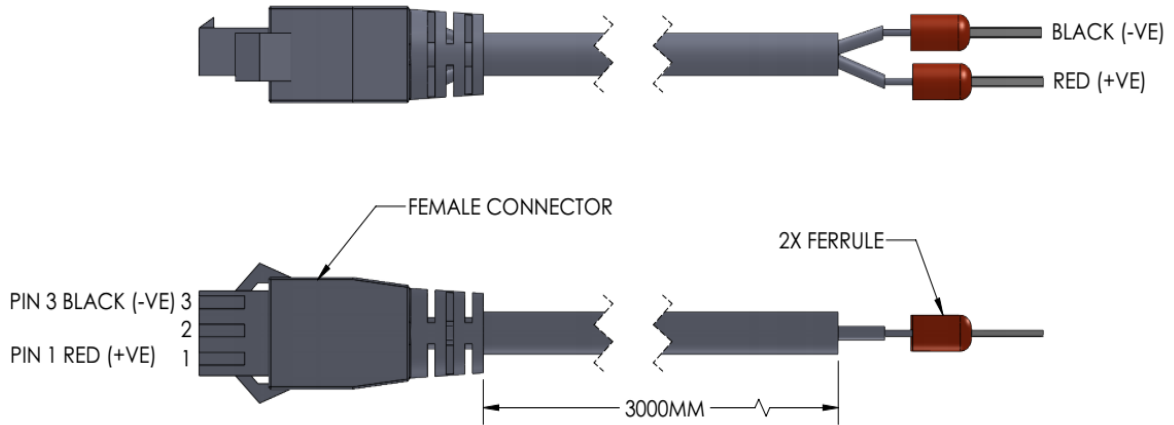

### II) EXT-FL-M12F-3M

Extension Cable of 3 Meter with M12 connector

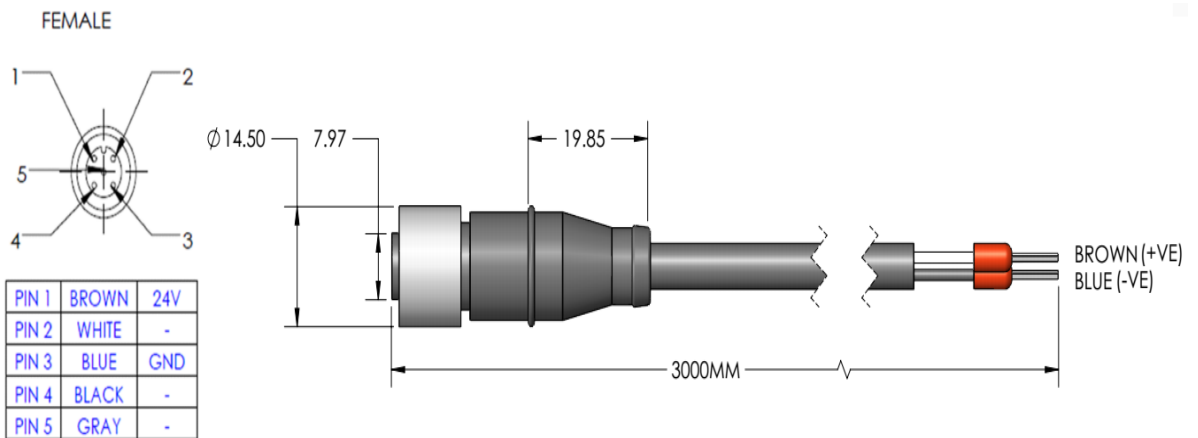

# General Description

## POWER CORD INFORMATION

The cable length is 1.8 Meter length of power cord.

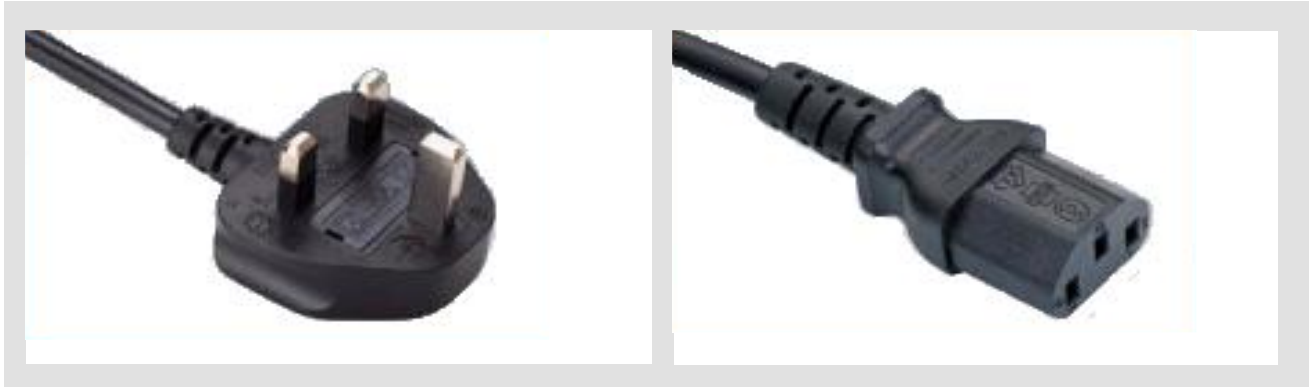

**240VAC Power Cord (UK)**

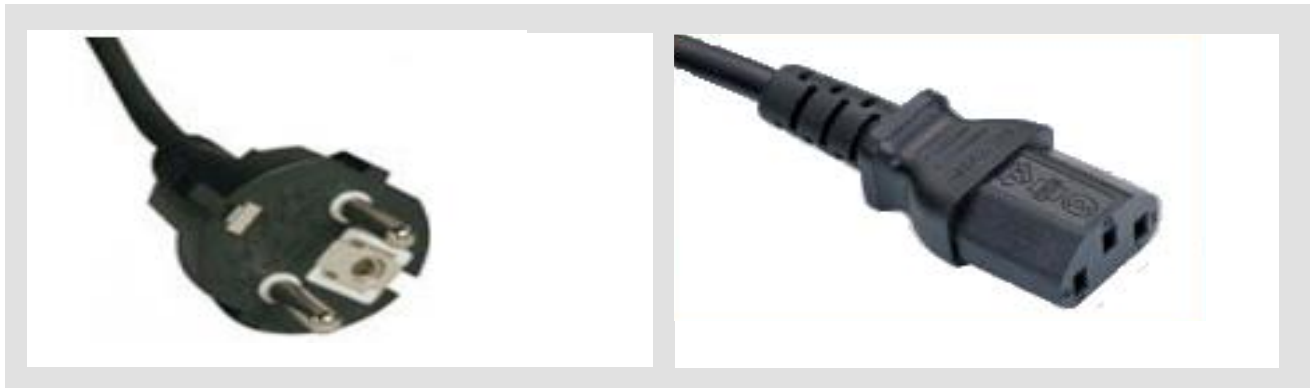

**220VAC Power Cord (EU)**

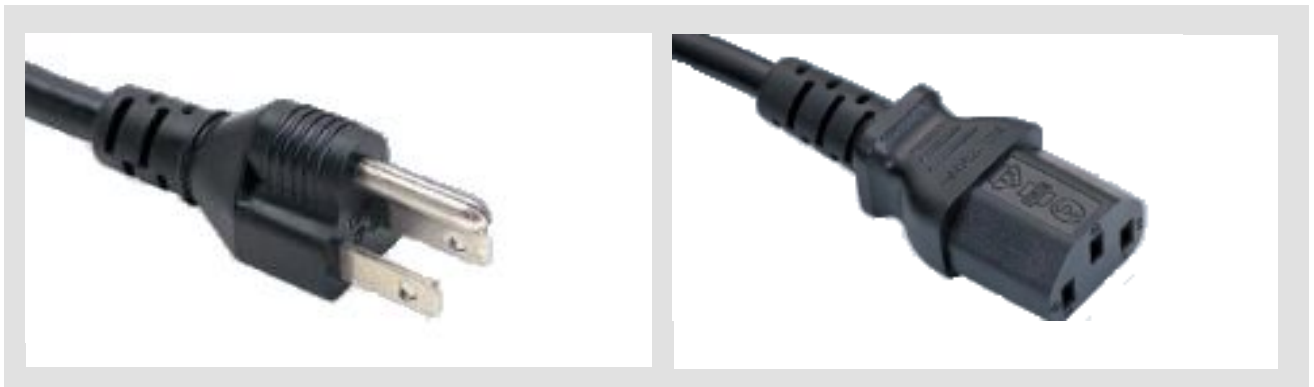

**110VAC Power Cord (US)**



# Contact us

Visionlux Technology Sdn Bhd  
No 1A-1, Tingkat Kenari 6, Desaria, Sungai  
Ara, 11900 Bayan Lepas, Penang,  
Malaysia

Tel: +04-6468428 | Fax: +04-6463428  
enquiry@visionlux.net  
www.visionlux.net

